

HMP-4005E

ELECTRIC LIFT

HMP-4005E

With Taiwan control system











FEATURES:

- * Weight capacity: 400 lbs safe working load.
- * Low base height standard.
- * Foot pedal can be easily opened and closed by foot so needn't control it by busy hands.
- * Battery system with low charge and load capacity warnings.
- * Optional HMP-S200 scale attachment available.
- * Demark control system available.

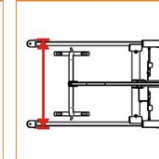
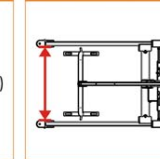
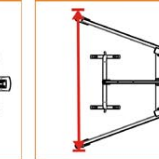
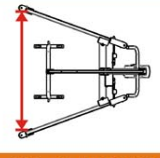
Made in Taiwan

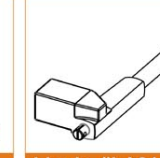

SPECIFICATION:

WEIGHT CAPACITY	MAX. HEIGHT	MIN. HEIGHT	BASE CLOSED EXTERNAL WIDTH	BASE CLOSED INTERNAL WIDTH	BASE OPEN EXTERNAL WIDTH
 400 Lbs (180 KGS)	 65" (165 CM)	 15.5" (39 CM)	 26.5" (67 CM)	 22" (56 CM)	 38" (97 CM)
BASE OPEN INTERNAL WIDTH	BASE HEIGHT CLEARANCE	MAST HEIGHT	OVERALL LENGTH	ACTUATOR	UNIT NET WEIGHT
 33.5" (90 CM)	 4.5" (11 CM)	 48" (122 CM)	 41" (104 CM)	 Linak #LA31 600kgs weight capacity	 114.5 Lbs (52 Kgs)

